

REVISIONS			
REV.	DESCRIPTION	DATE	BY

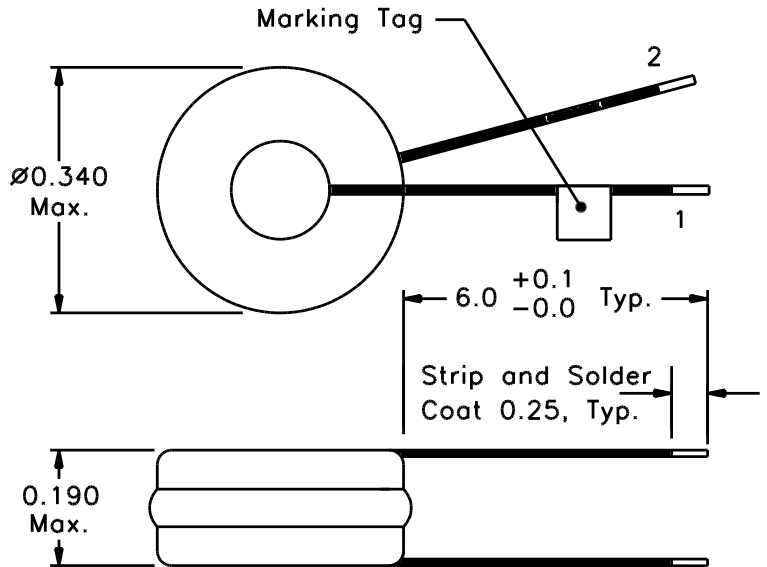

Classification

MIL-PRF-27 Grade: 6
 MIL-PRF-27 Class: S (130° C)
 Maximum Ambient Temperature: 105° C

MIL-STD-981 Quality Assurance Provisions

Class	Description	Drawing Number ¹
C	Commercial Parts	33008-30
B	Group A Inspection	33008-31B
E	Group A Inspection	33008-31S
S	Group A Inspection	33008-31S and
	Group B Inspection	33008-85

¹ The germane data will ship with the hardware.

<u>LOAD CONDITIONS</u>	
IDC (1 - 2) = 0.35 A	P _{TOTAL} < 0.2 W

Electrical Characteristics

DC Resistance: (1 - 2) = 70 mΩ Maximum

Inductance (measured at 0.1 V, 10 KHz):

(1 - 2) = 17.3 μH -10%, +18%, IDC = 0A

(1 - 2) = 15 μH Min., IDC = 0.35A

These Parts Are Manufactured in Strict Compliance to MIL-STD-981.

The "X" in the part number refers to the Quality Level (C, B, E, or S), see Quality Assurance Provisions above.	UNLESS OTHERWISE SPECIFIED: Dimensions are in inches, and tolerances are:		COAST/ACM		
	Fractions	Decimals	Angles	TITLE	
	±1/64	.X = ±0.1 .XX = ±0.03 .XXX = ±0.010	±10°	Inductor	
	DRAWN BY	DATE	FSCM	DWG. NO	REV.
	Jim Allen	07/30/03	22558	33008X	
DO NOT SCALE DRAWING			SCALE: none	MAX. WT.: 2.0 grams	SHEET 1 OF 1